

REV.	DATE	DESCRIPTION
NC	01/14/03	INITIAL RELEASE
A	04/19/06	REVISE CONTACT PIN MATERIAL AND PLATING
B	05/07/06	REVISE INSULATOR MATERIAL TO DELRIN

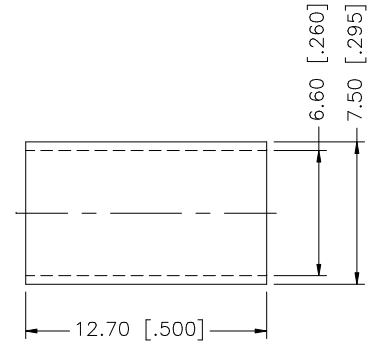
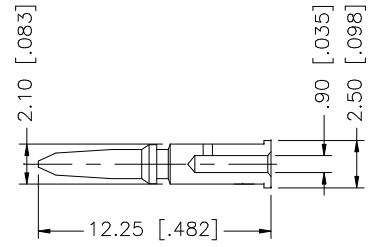
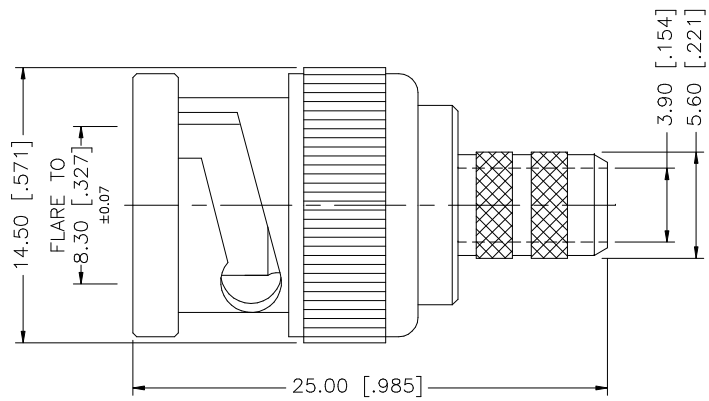
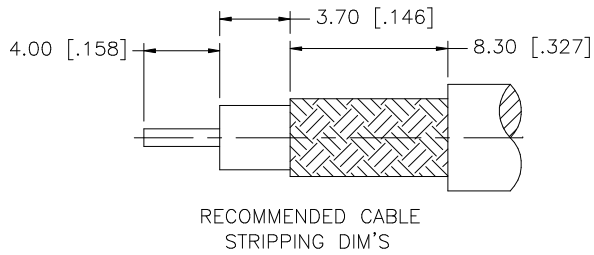

CRIMP NOTES:

1. CRIMPED FERRULE  
HEX CRIMP SIZE .255"
2. CRIMPED CONTACT PIN  
HEX CRIMP SIZE .068"

8				
7				
6				
5				
4	FERRULE	BRASS	NICKEL	1
3	INSULATOR	DELTRIN	NATURAL	1
2	CONTACT PIN	BRASS	GOLD	1
1	HOUSING/BODY	BRASS	NICKEL	1
	DESCRIPTION	MATERIAL	FINISH	QTY

UNLESS OTHERWISE SPECIFIED DIMENSIONS ARE IN MILLIMETERS. DIMENSIONS IN [ ] ARE IN INCHES AND FOR CUSTOMER REFERENCE ONLY.

UNLESS OTHERWISE SPECIFIED TOLERANCES FOR MILLIMETERS ARE:  
0.5 - 8mm ± 0.20mm  
8 - 30mm ± 0.40mm  
30 - 120mm ± 0.50mm

UNLESS OTHERWISE SPECIFIED TOLERANCES FOR INCHES ARE:  
.020 - .315 ± 0.007"  
.315 - 1.180 ± 0.015"  
1.180 - 4.724 ± 0.020"

DO NOT SCALE DRAWING

APPROVALS	DATE
DRAWN G.R.S.	05/07/06
CHECKED	
ISSUED	
SHEET 1 OF 1	
CAD FILE	C:/112/112507.DWG

**Amphenol Connex**

PART DESCRIPTION  
**BNC CRIMP PLUG – RG59/U 20AWG  
CENTER CONTACT – 75ohm**

PART NO.  
**112507**

DWG. NO.	112507.DWG	REV.	B	SIZE	A	SCALE	NA
----------	------------	------	---	------	---	-------	----